

features

- Excellent anti-sulfuration characteristic due to using high sulfuration-proof inner top electrode material
- High heat resistance that can be used even at high temperatures of 155°C or higher. The maximum operating temperature of Sn plating products compatible with solder mounting is 175°C.
- Excellent heat resistance and weather resistance are ensured by the use of metal glaze thick film
- High stability and high reliability with the triple-layer structure of electrode
- Superior to RK73 series chip resistors pulse withstanding voltage and high power
- Applicable to various kinds of automatic mounters for taping, etc
- Products meet EU RoHS requirements. EU RoHS regulation is not intended for Pb-glass contained in electrode, resistor element and glass.
- AEC-Q200 Tested

dimensions and construction

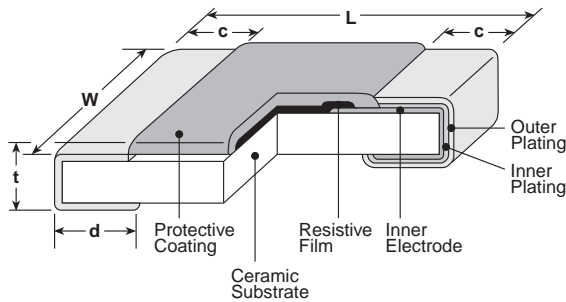

Type (Inch Size Code)	Dimensions inches (mm)				
	L	W	c	d	t
1E (0402)	.039 ^{+0.003} _{-.002} (1.0 ^{+0.1} _{-0.05})	.020±.002 (0.5±0.05)	.008±.006 (0.2±0.15)	.010 ^{+0.002} _{-.004} (0.25 ^{+0.05} _{-0.1})	.014±.002 (0.35±0.05)
1J (0603)	.063±.008 (1.6±0.2)	.031±.004 (0.8±0.1)	.012±.006 (0.3±0.15)	.012±.004 (0.3±0.1)	.018±.004 (0.45±0.1)
2A (0805)	.079±.008 (2.0±0.2)	.049±.004 (1.25±0.1)	.016±.010 (0.4±0.25)	.012 ^{+0.008} _{-.004} (0.3 ^{+0.2} _{-0.1})	.02±.004 (0.5±0.1)
2B (1206)	.126±.008 (3.2±0.2)	.063±.008 (1.6±0.2)	.022±.014 (0.55±0.35)	.016 ^{+0.008} _{-.004} (0.4 ^{+0.2} _{-0.1})	.024±.004 (0.6±0.1)

ordering information

HSG73P	2B	R	T	TD	103	J
Type	Power Rating	Characteristic	Terminal Surface Material	Packaging	Nominal Resistance	Tolerance
	1E: 0.125W, 0.2W ^{*1} 1J: 0.2W, 0.33W ^{*1} 2A: 0.25W, 0.5W ^{*1} 2B: 0.33W, 0.75W ^{*1}	R: Anti-Sulfuration	T: Sn	TP: 2mm pitch punch paper TD: 4mm pitch punched paper For further information on packaging, please refer to Appendix A	F: 4 digits J: 3 digits	F: ±1% J: ±5%

*1 If you use at the rated power, please keep the condition that the terminal of the resistor is below the rated terminal part temperature.

Contact us when you have control request for environmental hazardous material other than the substance specified by EU RoHS.

Specifications given herein may be changed at any time without prior notice. Please confirm technical specifications before you order and/or use.

10/30/24

applications and ratings

Part Designation	Power Rating	Rated Ambient Temp.	Rated Terminal Part Temp.	T.C.R. (x10 ⁻⁶ /K) Max.	Resistance Range		Maximum Working Voltage	Maximum Overload Voltage
					F: ±1% E24	J: ±5% E24		
HSG73P1E (0402)	0.125W	70°C	125°C	±200	10Ω~1MΩ	1Ω~10MΩ	75V	100V
	0.2W ^{*1}	70°C	105°C					
HSG73P1J (0603)	0.2W	70°C	135°C	±200	10Ω~1MΩ	1Ω~10MΩ	150V	200V
	0.33W ^{*1}	70°C	125°C					
HSG73P2A (0805)	0.25W	70°C	125°C	±200	10Ω~1MΩ	1Ω~10MΩ	200V	400V
	0.5W ^{*1}	70°C	100°C					
HSG73P2B (1206)	0.33W	70°C	125°C	±200	10Ω~1MΩ	1Ω~10MΩ	200V	400V
	0.75W ^{*1}	70°C	105°C					

Operating Temperature Range :-55°C ~ +175°C

Rated voltage = $\sqrt{\text{Power rating} \times \text{resistance value}}$ or max. working voltage, whichever is lower

*1 If you use at the rated power, please keep the condition that the terminal of the resistor is below the rated terminal part temperature.

Please refer to the derating curves based on the terminal temperature.

If any questions arise whether to use the "Rated Ambient Temperature" or the "Rated Terminal Part Temperature" in your usage conditions, please give priority to the "Rated Terminal Part Temperature"

Derating Curve

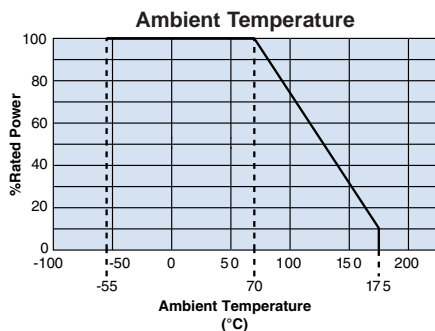

For resistors operated at an ambient temperature of 70°C or above, a power rating shall be derated in accordance with the derating curve.

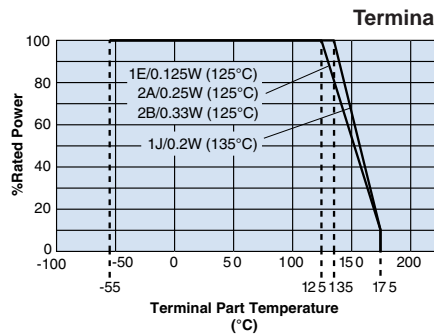

When the terminal part temperature of the resistor exceeds the rated terminal part temperature shown above, the power shall be derated according to the derating curve.

If you want to use at the rated power of *1, please use the derating curves based on the terminal part temperature side.

Please refer to "Introduction of the derating curves based on the terminal part temperature" in the beginning of our catalog before use.

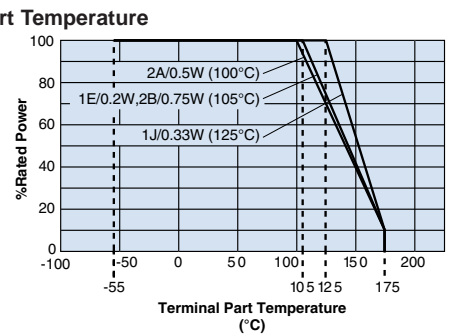

Temperature Rise

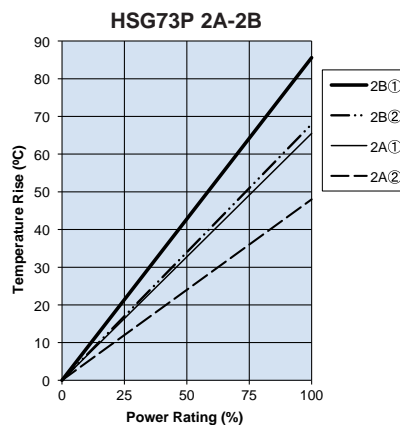
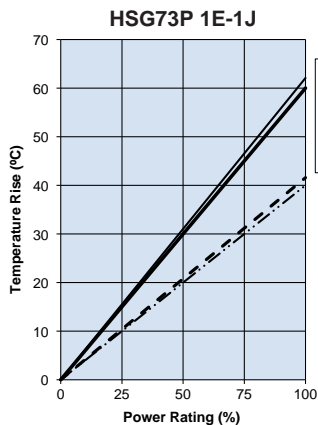

Regarding the temperature rise, the value of the temperature varies per conditions and board for use since the temperature is measured under our measuring conditions.

Measurement condition
Room temperature: 25°C
PCB: FR-4 t = 1.6mm
Cu foil thickness: 35μm

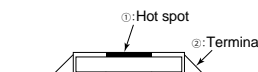

One-Pulse Limiting Electric Power

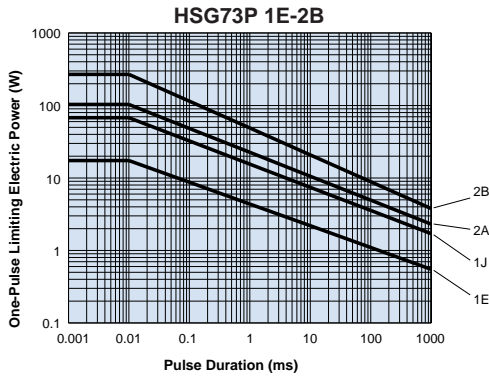

The maximum applicable voltage is equal to the max. overload voltage.
Please ask us about the resistance characteristic of continuous applied pulse.

environmental applications

Performance Characteristics

Parameter	Requirement $\Delta R \pm(\%+0.1\Omega)$		Test Method
	Limit	Typical	
Resistance	Within specified tolerance	—	25°C
T.C.R.	Within specified T.C.R.	—	+25°C/-55°C, +25°C/+125°C
Overload (Short time)	±2%	±0.5%	Rated voltage × 2.5 for 5s (2A: 0.5W, 2B: 0.75W: Rated voltage × 2 for 5s)
Rapid Change of Temperature	±0.5%	±0.3%	-55°C (30 min.)/+125°C (30 min.) 100 cycles
Moisture Resistance	±2%: 1J, 2A, 2B ±3%: 1E	±0.75%: 1J, 2A, 2B ±1%: 1E	40°C ± 2°C, 90%-95% RH, 1000 hours, 1.5 hr ON, 0.5 hr OFF cycle
Endurance at 70°C	±2%: 1J, 2A, 2B ±3%: 1E	±0.75%: 1J, 2A, 2B ±1%: 1E	70°C ± 2°C, 1000 hours, 1.5 hr ON, 0.5 hr OFF cycle
Endurance at 175°C	±1%	±0.3%	+175°C, 1000 hours, Power Rating×10%
Sufuration Test	±5%	±0.2%	Soaked in industrial oil with sulfur substance 3.5% contained, 105°C ± 3°C, 500 hours

Additional environmental applications can also be found at www.koaspeer.com